



Doosan Machine Tools

Doosan **Semiconductor** **Solution** **Reference**

ver. EN 210518 SU

Confidentiality:

This document is the intellectual property of Doosan Machine Tools.

Any revision, distribution or reproduction thereof is strictly prohibited unless otherwise approved by Doosan Machine Tools.

Doosan Application Business

Intro

Front-End Process

Vacuum Equipment
Splaying/Cleaning/
Heating
Polishing/
Metalization
Transfer System

Back-end Process

Wafer Inspection
Molding
Chip Inspection

Others

Frame/Cover



* Calculation based on KOMMA statistics(2017~2018)

Semiconductor Equipment Parts : Front-end Process

Intro

Front-End Process

- Vacuum Equipment
- Splaying/Cleaning/Heating
- Polishing/Metalization
- Transfer System

Back-end Process

- Wafer Inspection
- Molding
- Chip Inspection

Others

- Frame/Cover



Semiconductor Equipment Parts : Back-end Process

Intro

Front-End Process

Vacuum Equipment
Splaying/Cleaning/
Heating
Polishing/
Metalization
Transfer System

Back-end Process

Wafer Inspection
Molding
Chip Inspection

Others

Frame/Cover

Wafer Inspection Equipment

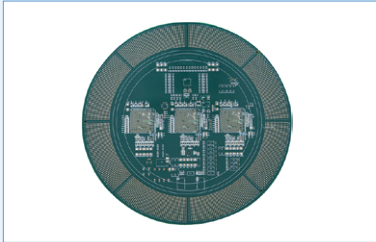

Probe Card

Chip Inspection Equipment



Test Socket

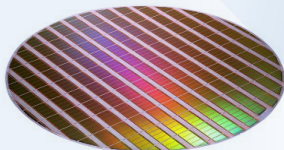

Wafer Inspection



| Packaging |

Wafer
Cutting

Wire
Bonding

Molding

Marking

Molding
Cutting



End product Inspection



Molding



Molding Die

Other parts



Frame

Korean Semiconductor Industry and Doosan Machine Tools

Intro

Front-End Process

- Vacuum Equipment
- Splating/Cleaning/Heating
- Polishing/Metalization
- Transfer System

Back-end Process

- Wafer Inspection
- Molding
- Chip Inspection

Others

- Frame/Cover

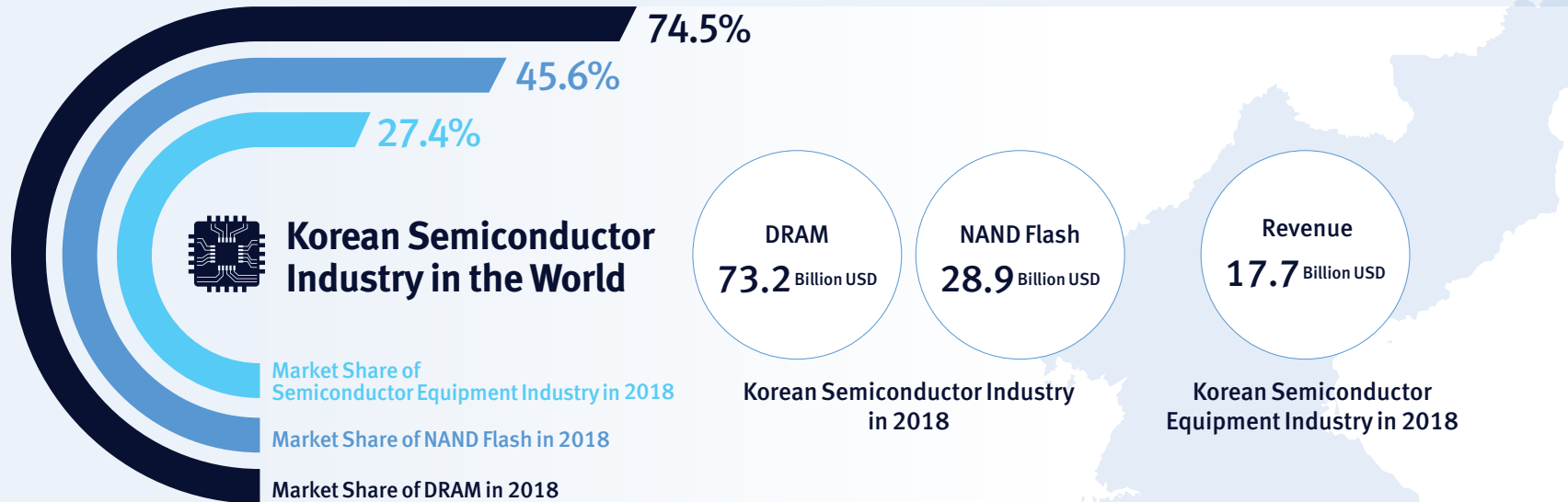

Doosan Machine Tools & Korean IT Industry

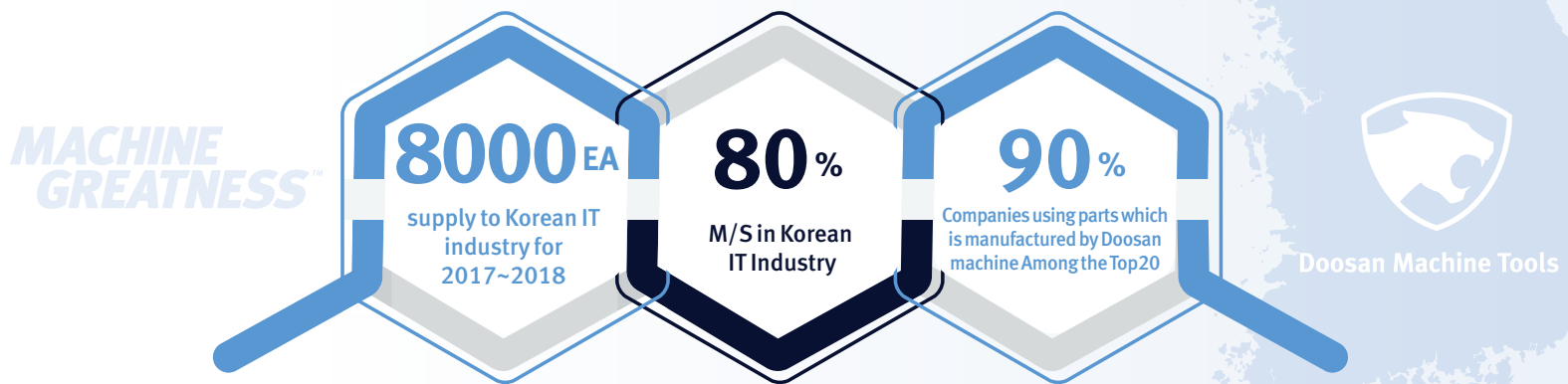



***Doosan
Semiconductor
Solution***

Index

* If you click the photo of parts, you can go to corresponding page

Front-end Equipment parts

Vacuum Equipment

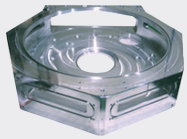

Chamber

Splaying/Cleaning/Heating

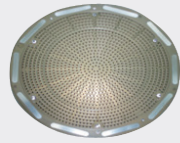

Showerhead

Polishing/Metalization



CMP pad

Transfer System



Quartz Boat

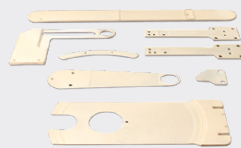

Robot Arm



Flange / Clamp



Ring



Sealing / Bellows



Heater

Back-end Equipment parts

Wafer Inspection Equipment

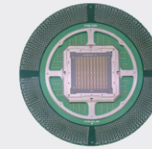

Probe Card

Molding

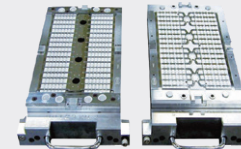

Molding Die

Chip Inspection Equipment

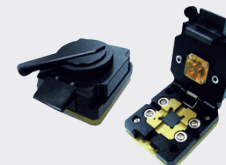

Test Socket

Other Equipment parts

Other Equipment



Frame

Vacuum Equipment

Intro

Front-End Process

Vacuum Equipment
 Splaying/Cleaning/
 Heating
 Polishing/
 Metalization
 Transfer System

Back-end Process

Wafer Inspection
 Molding
 Chip Inspection

Others

Frame/Cover

Workpiece

Chamber



Material
Stainless Steel
Aluminum

Manufacturing Specialty

Heavy duty

High Rigidity :
 In many cases,
 continuously operated for long periods

Precision: To maintain Vacuum condition

Solution

NHM series

Horizontal Machining Center

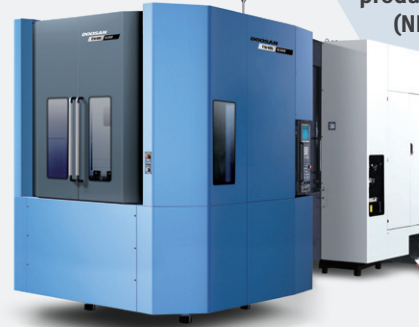
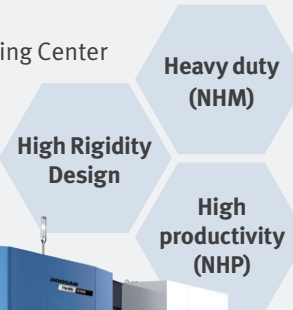

DCM II series

Multi-functional Bridge-type
 Machining Center

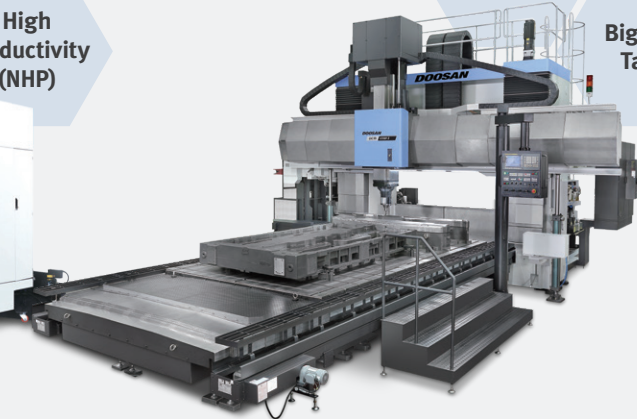
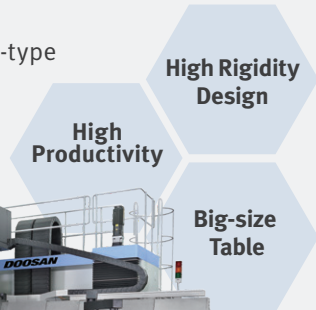

High Rigidity Bed Structure

NHM Series is designed for keeping high stability and durability intact through FEM technologies; the series ensures continuous powerful cutting power with the structure applied with M- and W-type ribs



W-type rib

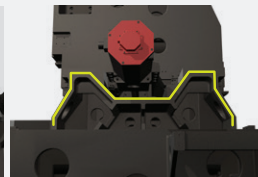

M-type rib

Adoption of ram spindle and saddle structure to support heavy-duty cutting

The highly rigid, square type box guideway ram has a cross section of 380 x 380mm(14.96x 14.96 inch), which is the biggest in its class. This ensures optimum heavy duty machining capability in both vertical and horizontal applications



Vacuum Equipment

Intro

Front-End Process

Vacuum Equipment
Splaying/Cleaning/
Heating
Polishing/
Metalization
Transfer System

Back-end Process

Wafer Inspection
Molding
Chip Inspection

Others

Frame/Cover

Workpiece

Flange / Clamp



Material

Stainless Steel / Ceramics
Aluminum / Inconel

Manufacturing Specialty

High Precision

Turning

Flexibility for various shapes

High Rigidity : Difficult-to-cut material

Solution

PUMA GT series

Global standard Horizontal
Turning Center

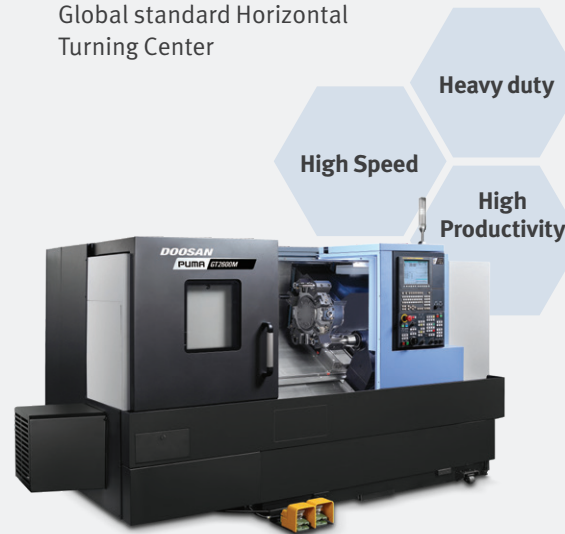

Cutting Performance

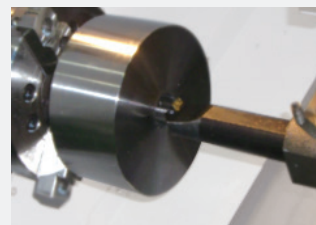

ID Turning Tool length

PUMA GT2100
3.5D

PUMA GT2600
3.5D

PUMA GT3100
4.0D

	PUMA GT2100	PUMA GT2600	PUMA GT3100
Cutting speed (m/min)	270(10629.9 ipm)	270(10629.9 ipm)	280(11023.6 ipm)
Feedrate (mm/rev)	0.3	0.3	0.3
Spindle speed (r/min)	1131	1131	849
Cutting depth (mm)	3 (0.1inch)	3 (0.1inch)	3 (0.1inch)

Mynx series

Heavy Duty Vertical
Machining Center



Improved Spindle Structure

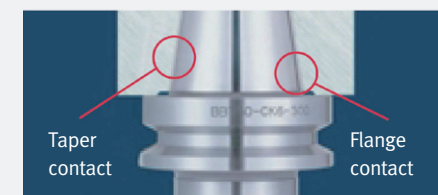

Dual Contact Spindle

The system enables simultaneous dual-contact of tapered side using elastic deformation of the spindle and perfect gauge control

Vacuum Equipment

Intro

Front-End Process

Vacuum Equipment
 Splaying/Cleaning/
 Heating
 Polishing/
 Metalization
 Transfer System

Back-end Process

Wafer Inspection
 Molding
 Chip Inspection

Others

Frame/Cover

Workpiece

Sealing / Bellows



Material

**Stainless Steel / Ceramics /
 Aluminum**

Manufacturing Specialty

High Precision

Flexibility for various shapes

Solution

DNM series

Global Standard Vertical Machining Center



Wide machining area

Wide machining area

DNM 4500/L
1000{1050} x 450mm
 (39.4{41.3} x 17.7 inch)

DNM 5700/L
1300{1050} x 570mm
 (51.2{59.1} x 21.3 inch)

DNM 6700/L/XL
1500{1600/2200} x 670mm
 (59.1{63.0/86.6} x 26.4 inch)

Max weight on Table

DNM 4500/4500L
600kg (1322.8 lb)

DNM 5700/5700L
1000kg (2204.6 lb)

DNM 6700/6700L/6700XL
1300kg (2866.0 lb)

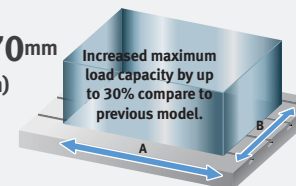

Cutting Performance

Chip removal rate cm ³ /min (inch ³ /min)	Spindle speed (r/min)	Feedrate mm/min (ipm)	
Face mill (ø80mm(3.15 inch)) Carbon steel (SM45C)			
527 (32.2)	1500	2700 (106.3)	3.1mm (0.1 inch)
Face mill (ø80mm(3.15 inch)) Aluminium(AL6061)			
1901 (116.0)	1500	5940 (233.9)	5mm (0.2 inch)
End mill (ø30mm (1.2 inch)) Carbon steel (SM45C)			
48 (2.9)	222	107 (4.2)	15mm (1.6 inch)
U-Drill (ø50mm(2.0 inch)) Carbon steel (SM45C)			
501 (30.6)	1500	255 (10.0)	150mm (6.0 inch)
Tap Carbon steel (SM45C)			
Tap size(mm) M 36 x P 4.0	221	884 (34.8)	

Vacuum Equipment

Intro

Front-End Process

Vacuum Equipment
Splaying/Cleaning/
Heating
Polishing/
Metalization
Transfer System

Back-end Process

Wafer Inspection
Molding
Chip Inspection

Others

Frame/Cover

Workpiece

Vacuum Pump Housing

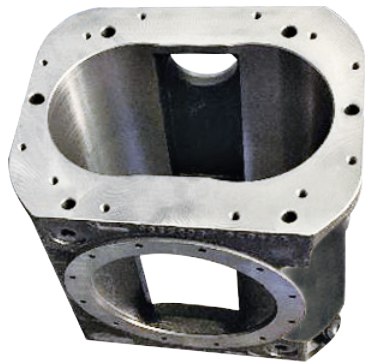

Material
Metal

Manufacturing Specialty

High hardness

High precision

Stable mass production

Solution

NHM series

High Capability Horizontal Machining Center

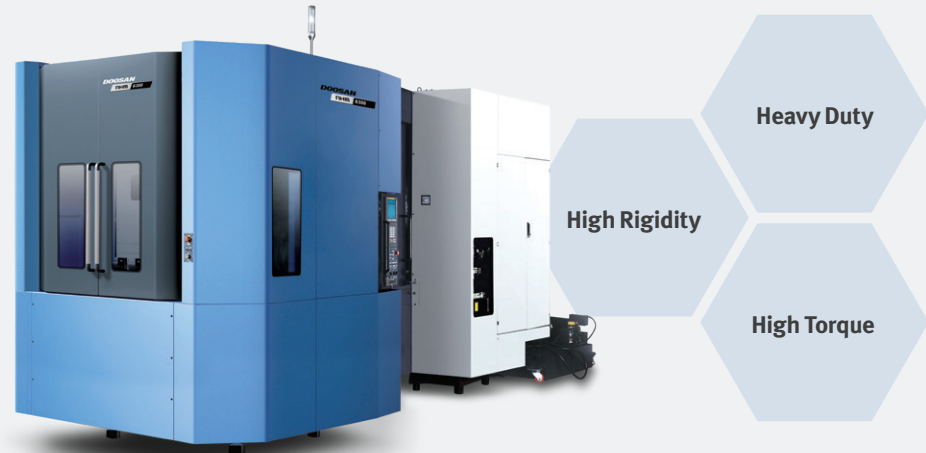

Powerful Spindle

Designed to minimize vibration and thermal error while offering rapid acceleration and deceleration, the spindle guarantees excellent cutting performance from steel to nonferrous metal parts.



Model	Rotation rate r/min	Output kW (Hp)	Torque N·m (ft·lb)	Specification
NHM 5000	6000	15 / 25	1034	ISO #50
NHM 6300		(20.1 / 33.5)	(25.8)	
NHM 8000		22 / 35	1732	
		(29.5 / 46.9)	(1277.5)	

Max. Workpiece Size

The NHM Series provides more space for heavier and larger workpieces.

	Max. workpiece size (D X H)	
NHM 5000	mm (inch)	Ø 850 x 1100 (Ø 33.5 x 43.3)
NHM 6300	mm (inch)	Ø 1050 x 1350 (Ø 41.3 x 53.1)
NHM 8000	mm (inch)	Ø 1450 x 1550 (Ø 57.1 x 61)
Max. workpiece weight (W)		
NHM 5000	kg (lb)	800 (1763.7)
NHM 6300	kg (lb)	1200 (2645.5)
NHM 8000	kg (lb)	2000 (4409.2)

Vacuum Equipment

Intro

Front-End Process

Vacuum Equipment
Splaying/Cleaning/
Heating
Polishing/
Metalization
Transfer System

Back-end Process

Wafer Inspection
Molding
Chip Inspection

Others

Frame/Cover

Workpiece

Vacuum Pump Rotor shaft



Material
Metal

Manufacturing Specialty

High hardness

High precision

Eccentric machining

Solution

NHM series

High Capability Horizontal Machining Center



Servo-driven ATC

The ATC is capable of handling weight from 25kg to 30kg at high speed using a servo motor, and fast tool indexing and spindle positioning.



Model	Cutting Capacity Unit : mm (inch)	
	Max. tool diameter x Max. tool length	
NHM 5000	BT / CT / DIN	HSK
	320 x 530 (12.6 x 20.8)	320 x 600 (12.6 x 23.6)
NHM 6300	320 x 630 (12.6 x 24.8)	320 x 700 (12.6 x 27.6)
	320 x 630 (12.6 x 24.8)	320 x 700 (12.6 x 27.6)

Tool change time (tool weight of less than 12 kg (26.5 lb))		
Model	Tool to tool	Chip to chip
NHM 5000	2 s	6.4 s
NHM 6300		6.7 s
NHM 8000		8 s

Powerful Spindle

Designed to minimize vibration and thermal error while offering rapid acceleration and deceleration, the spindle guarantees excellent cutting performance from steel to nonferrous metal parts.



Spindle Cooling System

The spindle temperature is kept uniform by the cooling system.

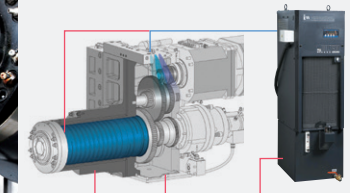

Fine Chip Protecting Solution

Intro

Front-End Process

Vacuum Equipment
Splaying/Cleaning/
Heating
Polishing/
Metalization
Transfer System

Back-end Process

Wafer Inspection
Molding
Chip Inspection

Others

Frame/Cover

PROTECT COVER(Bottom of X/Y-axis)

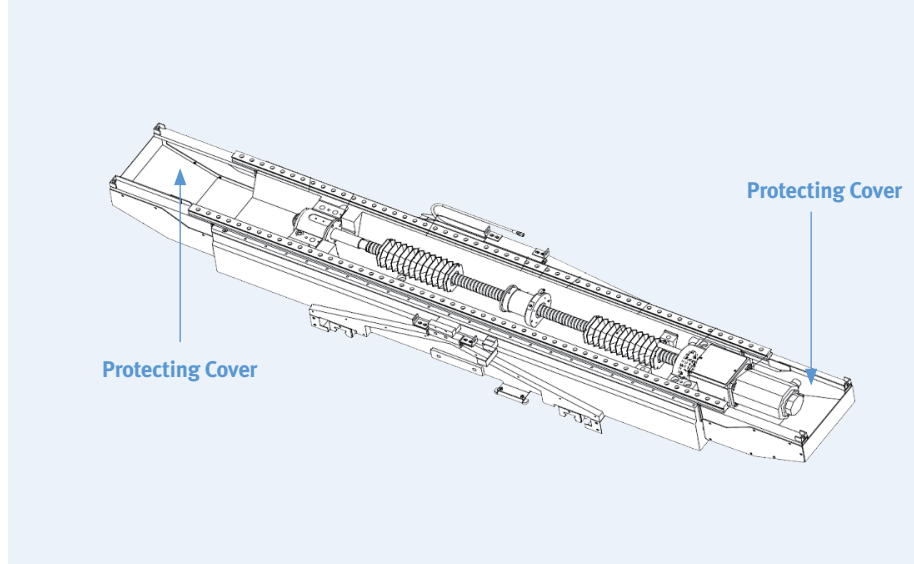

BALL SCREW COVER



LM GUIDE/GUIDE WAY Double WIPER

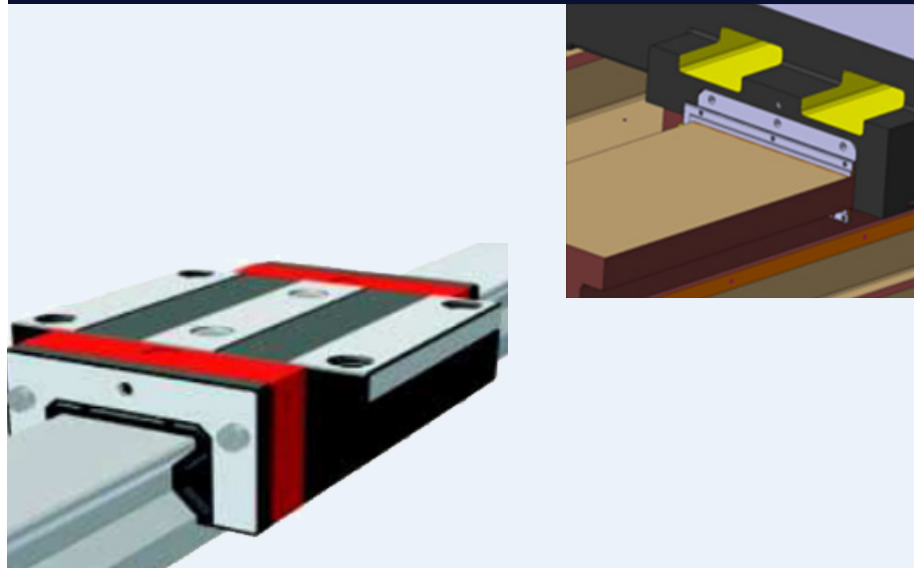

ATC Full Closed Cover

- Graphite : Essential
- Ceramics : Recommended

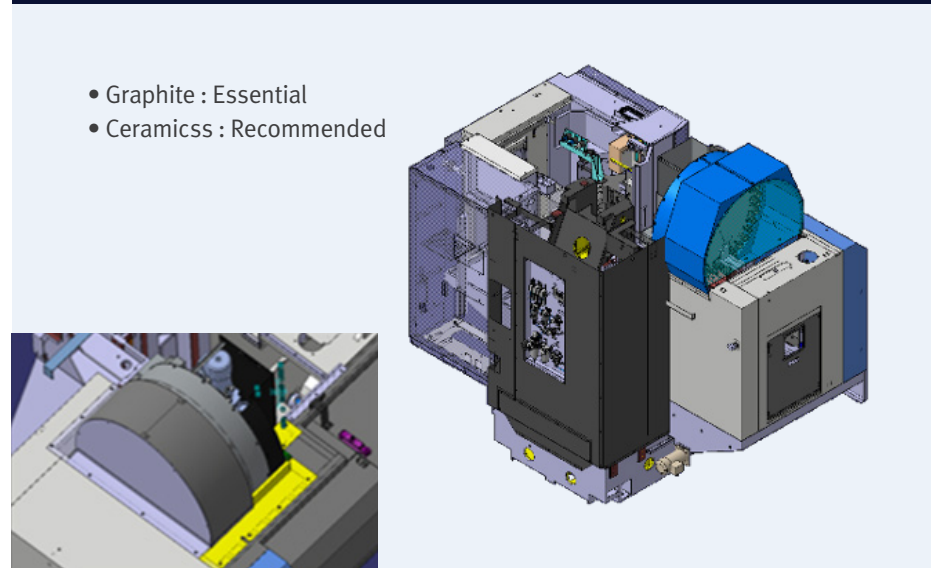

Fine Chip Protecting Solution(by material)

Intro

Front-End Process

Vacuum Equipment
 Splaying/Cleaning/
 Heating
 Polishing/
 Metalization
 Transfer System

Back-end Process

Wafer Inspection
 Molding
 Chip Inspection

Others

Frame/Cover

Ceramics : wet machining

Very hard & fine chip scattering :
 Dustproof structure

Tool wear by low thermal conductivity :
 Efficient coolant supply

Nonmagnetic fine chip :
 Good filtering needed

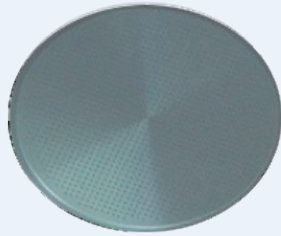

- BELLOWS COVER(X/Y)



- TABLE COVER_recommended **option**

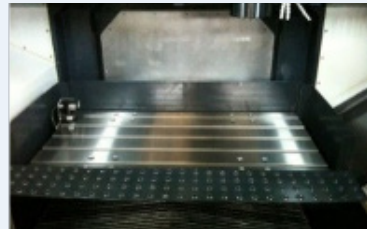

- SLIDE COVER (SUS)_recommended **option**

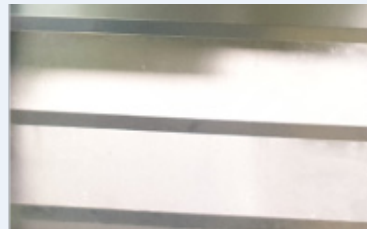

Graphite : Dry machining

Self lubricity : Dustproof structure

Low cutting resistance & high thermal conductivity : No need for wet machining

Fine chip scattering : Dustproof & Collection



- GREASE LUB



- AIR-OIL SUCTION

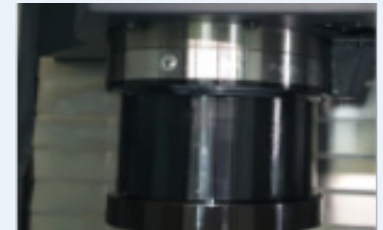

- Mist Collector for graphite (recommended) **option**

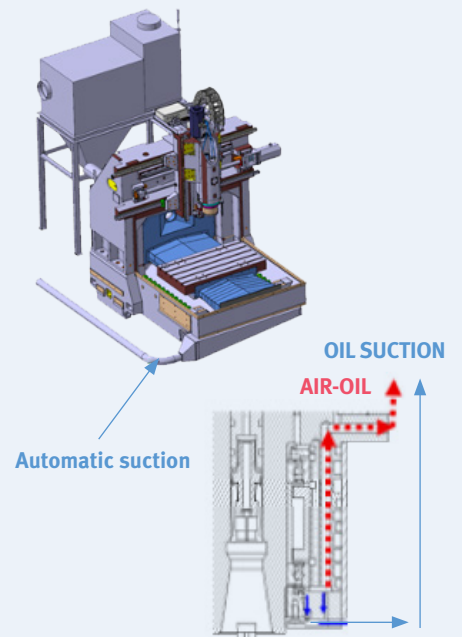

Intro

Front-End Process

Vacuum Equipment
Splaying/Cleaning/Heating
Polishing/Metalization
Transfer System

Back-end Process

Wafer Inspection
Molding
Chip Inspection

Others

Frame/Cover

Workpiece

Heater (plate)

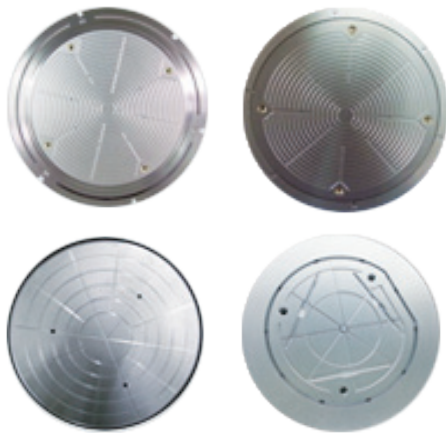

Material

**Stainless Steel / Ceramics
Aluminum**

Manufacturing Specialty

High Precision

Solutions to suit various materials

High hardness

Solution

Mynx II series

Heavy Duty Vertical Machining Center

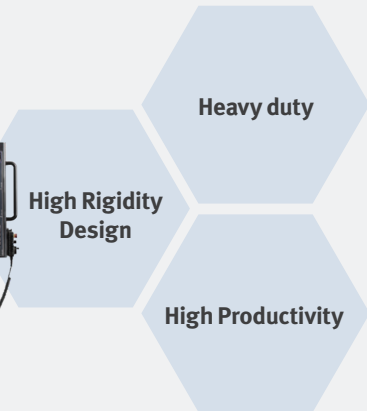

Drive System

The MynxII series spindles support Direct-driven, Belt-driven, Gear-driven, Built in-driven systems. Dual contact tool system support as standard

Models	Taper	Standard	Optional
Mynx 5400 II *** Mynx 6500 II *** Mynx 7500 II ***	ISO #40	8000r/min (15/11 kW (20.1/14.8 Hp), 286.5 N-m (211.4 ft-lbs))	12000r/min (15.6 kW (20.9 Hp), 165.5 N-m (122.1 ft-lbs))
Mynx 5400/50 II Mynx 6500/50 II	ISO #50	6000r/min (15/11 kW (20.1/14.8 Hp), 286.4 N-m (211.4 ft-lbs))	6000r/min (18.5/15 kW (24.8/20.1 Hp), 307.2 N-m (226.7 ft-lbs)) 6000r/min* (18.5/15 kW (24.8/20.1 Hp), 307.2 N-m (226.7 ft-lbs))
Mynx 7500/50 II	ISO #50	6000r/min (15/11 kW (20.1/14.8 Hp), 286.4 N-m (211.4 ft-lbs))	8000r/min (15/11 kW (20.1/14.8 Hp), 286.4 N-m (211.4 ft-lbs)) 6000r/min (18.5/15 kW (24.8/20.1 Hp), 307.2 N-m (226.7 ft-lbs)) 6000r/min* (18.5/15 kW (24.8/20.1 Hp), 307.2 N-m (226.7 ft-lbs))
Mynx 9500	ISO #50	6000r/min* 30/18.5 kW (40.2/24.8 Hp), 617.4 N-m (455.6 ft-lbs)	10000r/min** (30/25 kW (40.2/33.5 Hp), 420 N-m (310.0 ft-lbs))

None : Belt-driven * : Gear-driven ** : Built in-driven *** : Direct-driven



Mynx 9500 Gear driven spindles



Dual Contact Spindle

The system enables simultaneous dual-contact of tapered side using elastic deformation of the spindle and perfect gauge control.

Machining Stability : High Rigidity Box guideway



Surface Finish

The surface of moving elements are coated with Rulon 142 material to reduce friction and stick-slip. This material is carefully hand-scraped to achieve optimum accuracy.

Intro

Front-End Process

Vacuum Equipment
Splaying/Cleaning/
Heating
Polishing/
Metalization
Transfer System

Back-end Process

Wafer Inspection
Molding
Chip Inspection

Others

Frame/Cover

Workpiece

Heater



Material

AlN

Manufacturing Specialty

High hardness

High precision

Solution for Fine chip scattering

Solution

VX 6500C

Vertical Machining Center for ceramic machining

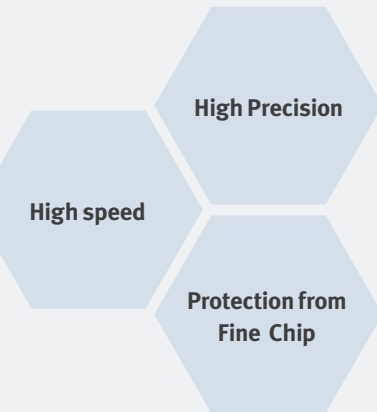

Basic structure

Max. spindle speed

12000r/min {20000/30000/40000} option

Travel distance

X axis **1050** mm
(41.3 inch)

Y axis **650** mm
(25.6 inch)

Z axis **550** mm
(21.7 inch)

Rapid traverse rate

X axis **30** m/mim
(1181.1 ipm)

Y axis **30** m/mim
(1181.1 ipm)

Z axis **30** m/mim
(1181.1 ipm)

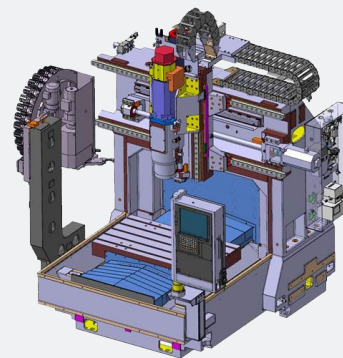

Realizes high-quality, high-precision machining with smoothing thermal displacement compensation of the spindle and structure.

Compensation of static displacement of spindle

Compensates in tool position caused by expansion of the spindle shaft at high speed.

Structure thermal displacement compensation

Compensates irregular deflection or expansion of the structure due to ambient temperature using a multiple temperature sensors.

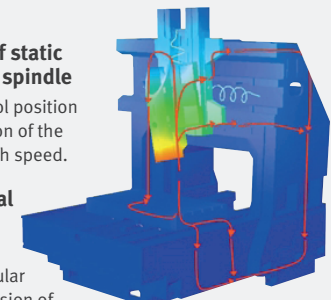

Intro

Front-End Process

Vacuum Equipment
Splaying/Cleaning/
Heating
Polishing/
Metalization
Transfer System

Back-end Process

Wafer Inspection
Molding
Chip Inspection

Others

Frame/Cover

Workpiece

Shower head

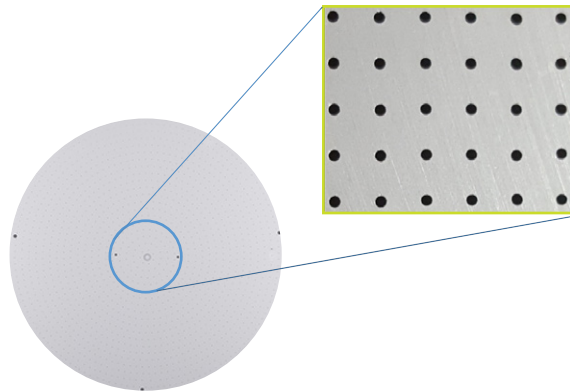

Material
Si

Manufacturing Specialty

High Precision

Repeat positioning accuracy

High speed spindle for hole roughness and protection from fine chip

Solution

T 4000HS

High Speed Tapping Center

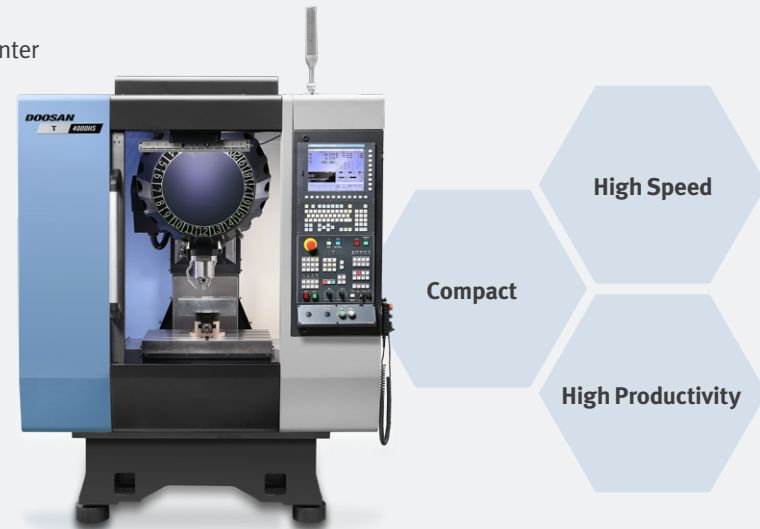

High speed machining solution

Max. Spindle speed
24000 r/min

New spindle cartridge

Oil-Lubrication for high reliability and endurance

Ultra-fine cutting: FANUC 31i

Rapid Traverse **48 m/min (1889.8 ipm)**



Spindle Thermal Error Compensation System (standard)

Thermal error of the spindle is calculated with the spindle temperature feedback and automatically compensated to maintain the highest level of work accuracy.

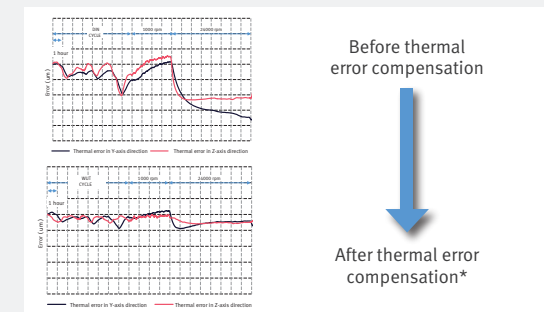

* T 4000, 18000 r/min, In-house measurement

Intro

Front-End Process

Vacuum Equipment
Splaying/Cleaning/
Heating
Polishing/
Metalization
Transfer System

Back-end Process

Wafer Inspection
Molding
Chip Inspection

Others

Frame/Cover

Workpiece

Shower head

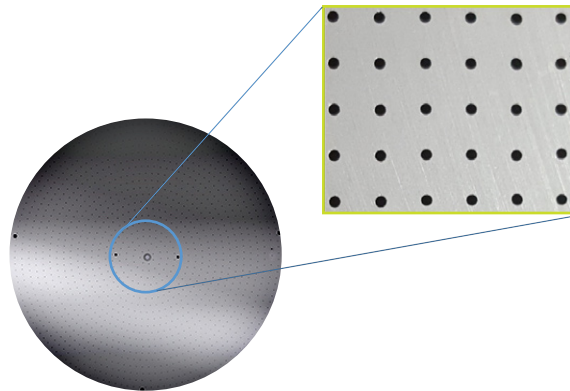

Material

**SiC, Aluminum, Si,
Ceramics, Quartz**

Machining Sample

Material : SiC

Thickness : 10mm

Hole size : \varnothing 0.3mm

Through-hole drilling both side by 6mm

Solution

VX 5500H

Vertical machining center for
fine hole machining



High Speed

High Precision

Fine Hole
Machining

Brigde frame for heavy duty

Travel distance

X axis **600 mm**
(23.6 inch)

Y axis **550 mm**
(21.7 inch)

Z axis **300 mm**
(11.8 inch)

Rapid Traverse

X/Y/Z axis

40 m/min
(1574.8 ipm)

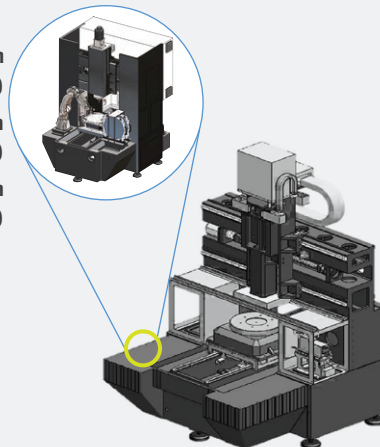

High speed spindle

Max. Spindle speed

40000 r/min HSK-E25

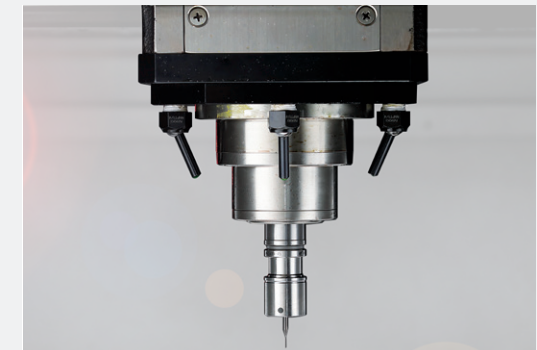

Intro

Front-End Process

Vacuum Equipment
Splaying/Cleaning/
Heating
Polishing/
Metalization
Transfer System

Back-end Process

Wafer Inspection
Molding
Chip Inspection

Others

Frame/Cover

Workpiece

Shower head

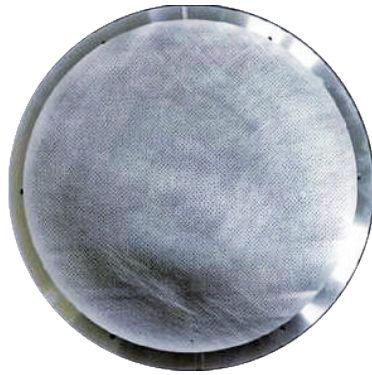

Material

Aluminum

Manufacturing Specialty

High hardness

High Precision

Solution for Fine chip scattering

Solution

MP 6500

High-Precision, High-Speed Vertical
Machining Center

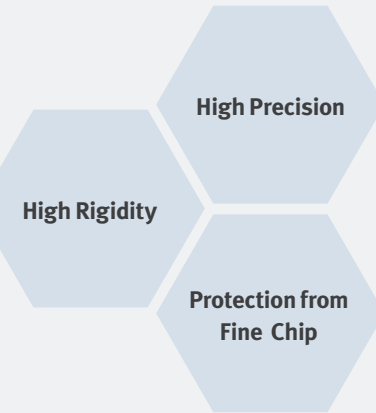

Bridge Type Structure

Thermal analysis of the symmetrical structure proves that this is the optimal solution for high precision machining of mild products.

Travel distance

X axis **1100 mm**
(43.3 inch)

Y axis **650 mm**
(25.6 inch)

Z axis **550 mm**
(21.7 inch)

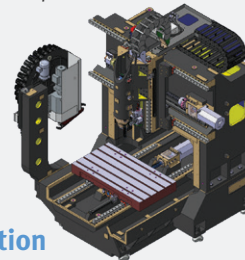

Recommended Option

Through Spindle Coolant

Linear scale

Oil Lubrication

High-rigidity, High-precision Spindle

Adopting a new constant preloading structure, improved spindle rigidity in low speed range and achieved long spindle life.

Max. spindle speed

20000 r/min
15000/30000/40000 r/min option

Spindle motor power

22/11 kW (29.5 / 14.8 Hp)



Spindle Cooling System

Cooling system removes heat generated at the bearings and motor to minimize thermal error. The air-oil structure supplies high pressure air and lubricant to the spindle bearings to remove the heat generated at the bearings and extend service life of the machine tool.

Intro

Front-End Process

Vacuum Equipment
Splaying/Cleaning/
Heating
Polishing/
Metalization
Transfer System

Back-end Process

Wafer Inspection
Molding
Chip Inspection

Others

Frame/Cover

Workpiece

SiC Ring



Material

SiC, Si, Ceramics, Quartz

Manufacturing Specialty

- High hardness
- High Precision
- Solution for Fine chip scattering
- Rotary table
- Stable mass production

Solution

VX 6500C

Vertical Machining Center for ceramic machining

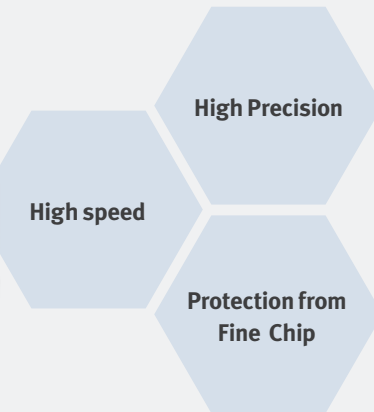

Basic structure

Max. spindle speed

12000r/min {20000/30000/40000} option

Travel distance

X axis **1050** mm
(41.3 inch)

Y axis **650** mm
(25.6 inch)

Z axis **550** mm
(21.7 inch)

Rapid traverse rate

X axis **30** m/mim
(1181.1 ipm)

Y axis **30** m/mim
(1181.1 ipm)

Z axis **30** m/mim
(1181.1 ipm)

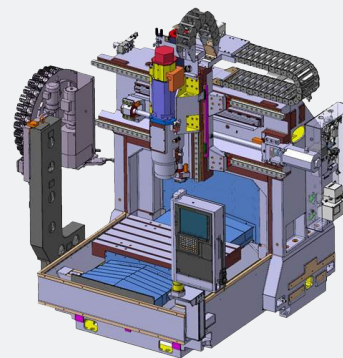

Realizes high-quality, high-precision machining with smoothing thermal displacement compensation of the spindle and structure.

Compensation of static displacement of spindle

Compensates in tool position caused by expansion of the spindle shaft at high speed.

Structure thermal displacement compensation

Compensates irregular deflection or expansion of the structure due to ambient temperature using a multiple temperature sensors.

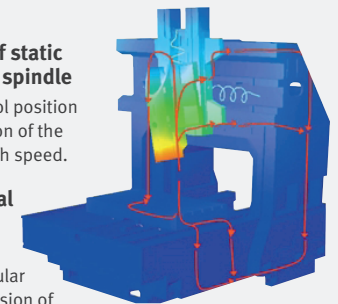

Intro

Front-End Process

Vacuum Equipment
Splaying/Cleaning/
Heating
Polishing/
Metalization
Transfer System

Back-end Process

Wafer Inspection
Molding
Chip Inspection

Others

Frame/Cover

Workpiece

Si Ring



Material
Si, Ceramics, Quartz

Manufacturing Specialty

High Precision

Solution for Fine chip scattering

Rotary table

Solution

DNM series

Global Standard Vertical Machining Center

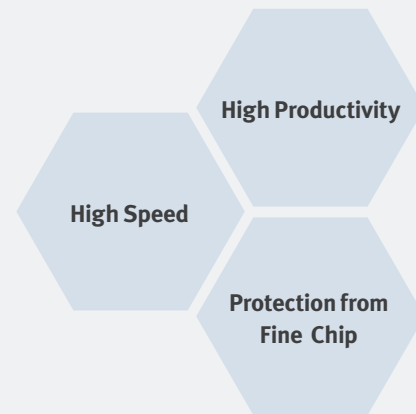

Various Spindle



Max. spindle speed

8000 r/min

12000 r/min Option

15000 r/min Option

Max. spindle motor power

18.5 kW (24.8 Hp)

Max. spindle motor torque

117.8 N·m (86.9 lbf·ft)

(8000 r/min, 12000 r/min,
15000 r/min)

286 N·m (211.1 lbf·ft) Option

(8000 r/min high torque version)

Rapid traverse rate (X / Y / Z axis)

DNM 4500 / 5700 / 6700 / 6700L

36/36/30 m/min (1417.3/1417.3/1181.1 ipm)

DNM 6700XL

30/30/30 m/min
(1417.3/1417.3/1181.1 ipm)

Grease lubrication for all
axes is a standard feature.

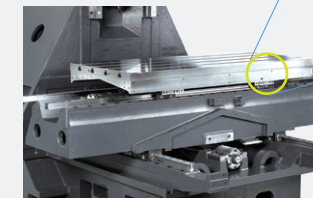

Roller-type LM Guides
are provided as a
standard feature.

Polishing/Metalization

Intro

Front-End Process

Vacuum Equipment
Splaying/Cleaning/
Heating
Polishing/
Metalization
Transfer System

Back-end Process

Wafer Inspection
Molding
Chip Inspection

Others

Frame/Cover

Workpiece

CMP Pad



Material Polyurethane

Manufacturing Specialty

Dry cutting

Maintain clean condition with dust collection

Vacuum Chuck clamping for polishing

Solution

PUMA VT series

High Performance Vertical Turning Center

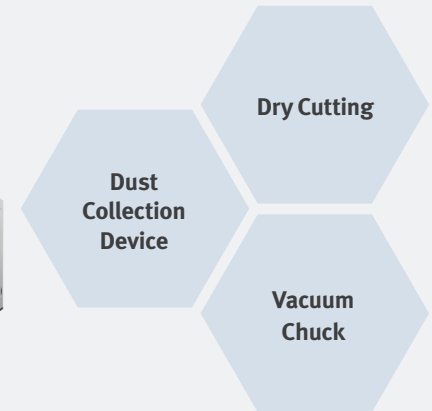

Heavy-duty Spindle

The best spindle power/torque in its class enables to achieve strong heavy-duty cutting performance.

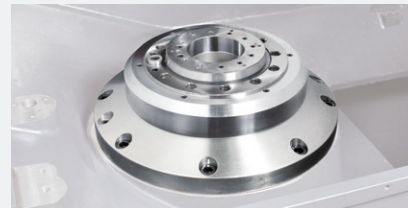

Max. spindle speed Max. torque
1800 r/min **4443** N.m (3278.9 ft-lbs)
Max. power (S3 60%/cont.)
45/37 kW (60.3 / 49.6 Hp)

Multi Dust Collection



Dust Collection Device 1
(Tool Post)

Dust Collection Device 2
(Spindle/Bed)

Intro

Front-End Process

Vacuum Equipment
 Splaying/Cleaning/
 Heating
 Polishing/
 Metalization
 Transfer System

Back-end Process

Wafer Inspection
 Molding
 Chip Inspection

Others

Frame/Cover

Workpiece

CMP Pad



Material

Polyurethane

Manufacturing Specialty

High speed machining

Stable mass production

Oil Air suction : Suction Pump

Solution

MP 6500

High-Precision, High-Speed Vertical
 Machining Center

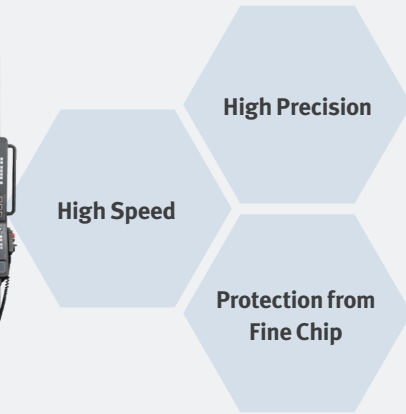

High-rigidity, High-precision Spindle

Adopting a new constant preloading structure, improved spindle rigidity in low speed range and achieved long spindle life.

Max. spindle speed
20000 r/min
 15000/30000/40000 r/min option
 Spindle motor power
22/11 kW (29.5 / 14.8 Hp)



Spindle Type and Tool Specification

Item	20000 r/min	15000 r/min <small>option</small>	30000 r/min <small>option</small>	40000 r/min <small>option</small>
Spindle motor power kW (Hp)	22 / 11 (29.5 / 14.8)	37 / 22 (49.6 / 29.5)	18.5 / 13 (24.8 / 17.4)	5.5 / 3.7 (7.4 / 5.0)
Taper spindle	BBT 40	BBT 40	HSK-F63	HSK-E40

Cutting Area

The size and load capacity of the table allow the setting up and cutting of larger workpieces of various shapes.

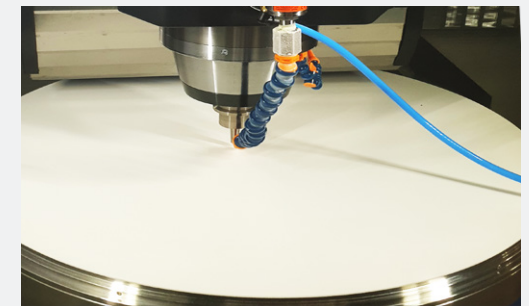

Item	Unit	MP 6500
Table size	mm (inch)	1200 x 650 (47.2 x 25.6)
Table loading capacity	kg (lb)	800 (1763.7)

Metalization

Intro

Front-End Process

Vacuum Equipment
Splaying/Cleaning/
Heating
Polishing/
Metalization
Transfer System

Back-end Process

Wafer Inspection
Molding
Chip Inspection

Others

Frame/Cover

Workpiece

Consumable for plating

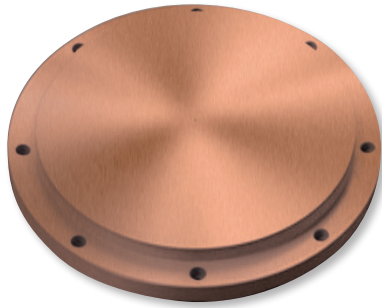

Material

Cooper, Aluminum, Titanium

Manufacturing Specialty

High Precision : Temperature control

High Precision : Height measurement

Mass production : Automation

Solution

PUMA V8300M

High Performance
Vertical Turning Center

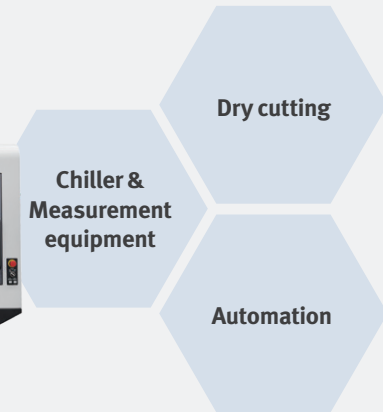

Automation Solution: Robot



Productivity Improvement

Reduction **11%** ↓

Old Process

New Process

Transfer System

Intro

Front-End Process

Vacuum Equipment
Splaying/Cleaning/
Heating
Polishing/
Metalization
Transfer System

Back-end Process

Wafer Inspection
Molding
Chip Inspection

Others

Frame/Cover

Workpiece

Quartz Boat



Material
Quartz

Manufacturing Specialty

High brittleness: Fragility

Needs heat treatment between machining operations

Mainly small hole machining

Solution

DNM series

Global Standard Vertical Machining Center

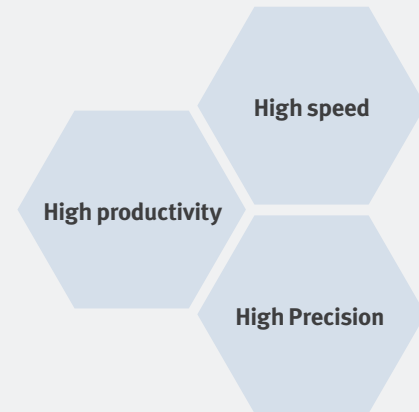

Travel distance (X x Y x Z axis)

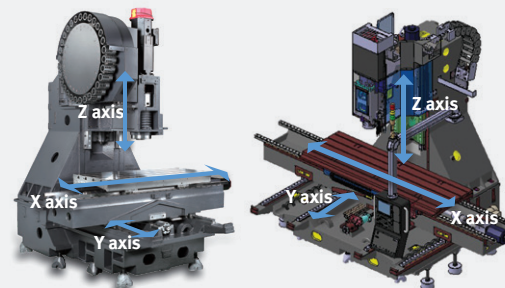

DNM 4500/L **800**{910} x **450** x **510** mm
(31.5{35.8} x 17.7 x 20.1 inch)

DNM 5700/L **1050**{1300} x **570** x **510** mm
(41.3{51.2} x 22.4 x 20.1 inch)

DNM 6700/L/X **1300**{1500/2100} x **670** x **625** mm
(51.2{59.1/82.7} x 26.4 x 24.6 inch)

Various Spindle



Max. spindle speed
8000 r/min
12000 r/min Option
15000 r/min Option

Max. spindle motor power
18.5 kW (24.8 Hp)

Max. spindle motor torque
117.8 N-m (86.9 lbf-ft)
(8000 r/min, 12000 r/min,
15000 r/min)

286 N-m (211.1 lbf-ft) Option
(8000 r/min high torque version)

Transfer System

Intro

Front-End Process

Vacuum Equipment
Splaying/Cleaning/
Heating
Polishing/
Metalization
Transfer System

Back-end Process

Wafer Inspection
Molding
Chip Inspection

Others

Frame/Cover

Workpiece

Quartz Ring



Material

Quartz, SiC, Ceramics

Manufacturing Specialty

High Precision grinding solution

Max. Dia \varnothing 300~550mm (\varnothing 11.8~21.7 inch) range
(for 300mm(11.8 inch) size wafer chamber)

Disposal of fine chips and sludge

Solution

Lynx XG 600/800 with ATC

Grinding machine for Quartz and Ceramics material



High
Precision
Grinding

Easy Sludge
Cleaning

C-axis Function
(Hole Machining)

Grinding

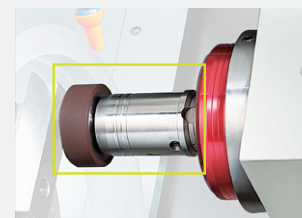
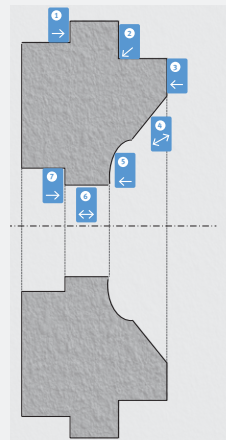

- 1 O.D. Groove Grinding
- 2 O.D. End face Grinding
- 3 Face Grinding
- 4 I.D. Taper Grinding
- 5 I.D. Curve Grinding
- 6 I.D. Grinding
- 7 I.D. Groove Grinding

Hole Machining (C-axis control) option



Grinding of holes and grooves on the front face and OD of the workpiece can now be achieved thanks to the addition of a C axis function on the main spindle.

- 1 Semicircular groove cutting
- 2 3 Hole machining
- 4 Keyway cutting

Transfer System

Intro

Front-End Process

Vacuum Equipment
Splaying/Cleaning/
Heating
Polishing/
Metalization
Transfer System

Back-end Process

Wafer Inspection
Molding
Chip Inspection

Others

Frame/Cover

Workpiece

Robot Arm

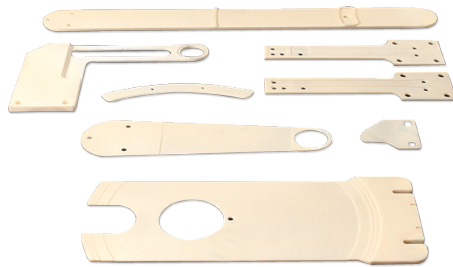

Material

Various Ceramicss

Manufacturing Specialty

High brittleness: Fragility

Flexibility for various shapes

Solution

DNM series

Global Standard Vertical Machining Center



Travel distance (X x Y x Z axis)

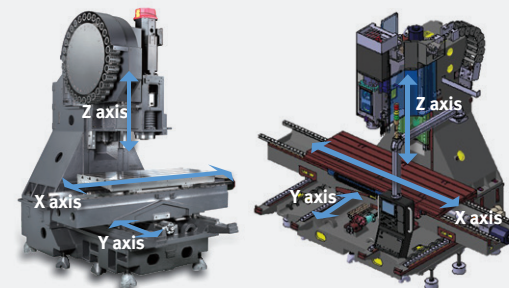

DNM 4500/L	800{910} x 450 x 510 mm (31.5{35.8} x 17.7 x 20.1 inch)
DNM 5700/L	1050{1300} x 570 x 510 mm (41.3{51.2} x 22.4 x 20.1 inch)
DNM 6700/L/X	1300{1500/2100} x 670 x 625 mm (51.2{59.1/82.7} x 26.4 x 24.6 inch)

Various Spindle



Max. spindle speed	8000 r/min 12000 r/min <small>Option</small> 15000 r/min <small>Option</small>
Max. spindle motor power	18.5 kW (24.8 Hp)
Max. spindle motor torque	117.8 N-m (86.9 lbf-ft) (8000 r/min, 12000 r/min, 15000 r/min)
	286 N-m (211.1 lbf-ft) <small>Option</small> (8000 r/min high torque version)

Wafer Inspection

Intro

Workpiece

Front-End Process

Vacuum Equipment
 Splaying/Cleaning/
 Heating
 Polishing/
 Metalization
 Transfer System

Probe Card

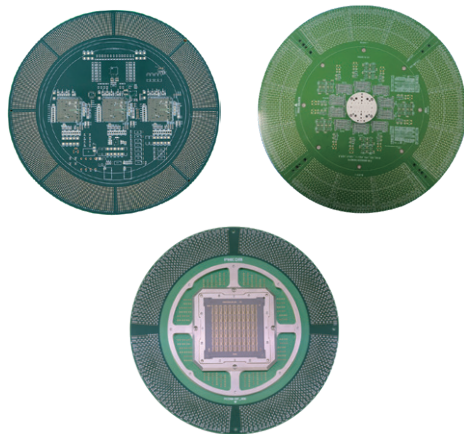

Back-end Process

Wafer Inspection
 Molding
 Chip Inspection

Others

Frame/Cover

Material Ceramics

Manufacturing Specialty

Solution for Ceramics

Small hole machining: 3~5mm (0.12~0.20inch)

Laser machining for smaller hole

Solution

Mynx II series

Heavy Duty Vertical Machining Center

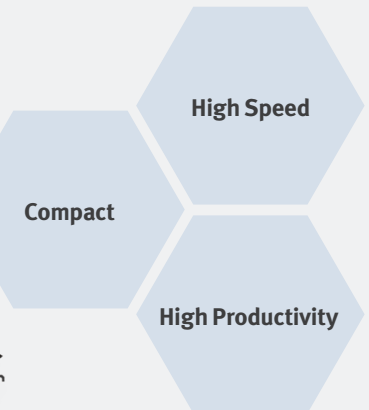

How to machine

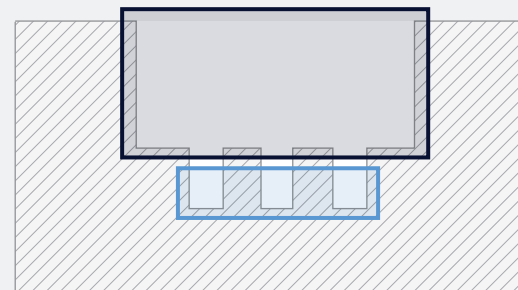

By Machine Tools

By Laser

*The results, indicated in this catalogue are provided as example. They may not be obtained due to differences in cutting conditions and environmental conditions during measurement.

Small hole machining : #40

ISO #40 Result of cutting test on Mynx 5400 II (8000r/min, Direct, 15/11kW (20.1/14.8 Hp))

Face mill (ø80 mm, Cut edge count :6) Carbon steel (SM45C)

Machining rate (cm ³ /min (inch ³ /min))	Spindle speed (r/min)	Feedrate (mm/min (ipm))
374.4 (22.8)	500	1950 (76.8)

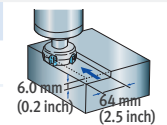

Drill (ø50 mm) Carbon steel (SM45C)

Machining rate (cm ³ /min (inch ³ /min))	Spindle speed (r/min)	Feedrate (mm/min (ipm))
265.07 (16.2)	500	135 (5.3)

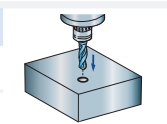

Tap Carbon steel (SM45C)

Tap size (mm (inch))	Spindle speed (r/min)	Feedrate (mm/min (ipm))
M36 x P4.0 (M1.4 x P0.2)	265	1060 (41.7)

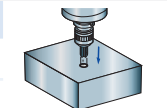

Molding Die

Intro

Front-End Process

Vacuum Equipment
 Splaying/Cleaning/
 Heating
 Polishing/
 Metalization
 Transfer System

Back-end Process

Wafer Inspection
 Molding
 Chip Inspection

Others

Frame/Cover

Workpiece

Molding Die

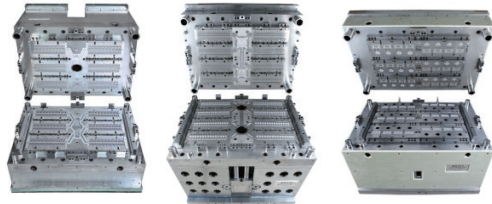
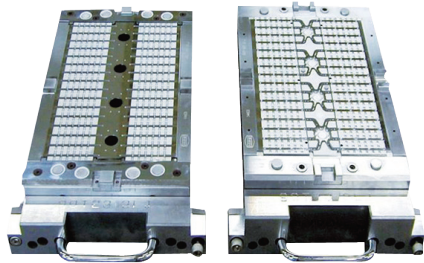

Material
Metal

Manufacturing Specialty

Ultra High Precision

Fine hole machining :
 Molding liquid must be equally injected

Solution

DNM series

Global Standard Vertical Machining Center

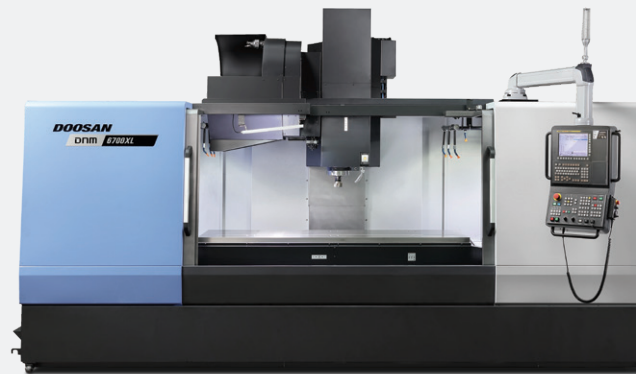

Wide

Wide machining area

DNM 4500/L
1000{1050} x 450mm
 (39.4{41.3} x 17.7 inch)

DNM 5700/L
1300{1050} x 570mm
 (51.2{59.1} x 21.3 inch)

DNM 6700/L/XL
1500{1600/2200} x 670mm
 (59.1{63.0/86.6} x 26.4 inch)

Max weight on Table

DNM 4500/4500L
600kg (1322.8 lb)

DNM 5700/5700L
1000kg (2204.6 lb)

DNM 6700/6700L/6700XL
1300kg (2866.0 lb)

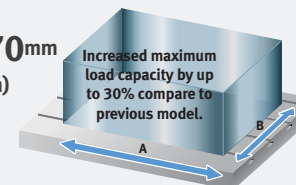

Various Spindle



Max. spindle speed

8000 r/min
12000 r/min Option
15000 r/min Option

Max. spindle motor power

18.5 kW (24.8 Hp)

Max. spindle motor torque

117.8 N-m (86.9 lbf-ft)
 (8000 r/min, 12000 r/min,
 15000 r/min)

286 N-m (211.1 lbf-ft) Option
 (8000 r/min high torque version)

Chip Inspection

Intro

Front-End Process

Vacuum Equipment
Splaying/Cleaning/
Heating
Polishing/
Metalization
Transfer System

Back-end Process

Wafer Inspection
Molding
Chip Inspection

Others

Frame/Cover

Workpiece

Test Socket

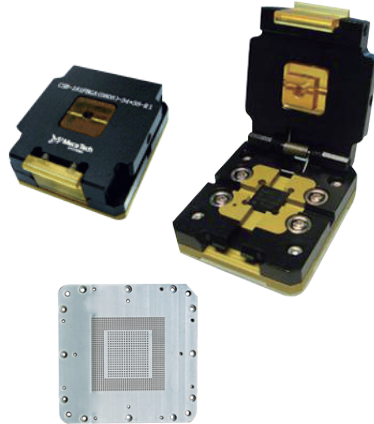

Material

Engineering Plastic / PEEK

Manufacturing Specialty

Small parts

High precision

Repeat positioning accuracy

High speed spindle for hole roughness

Solution

T 4000HS

High Speed Tapping Center

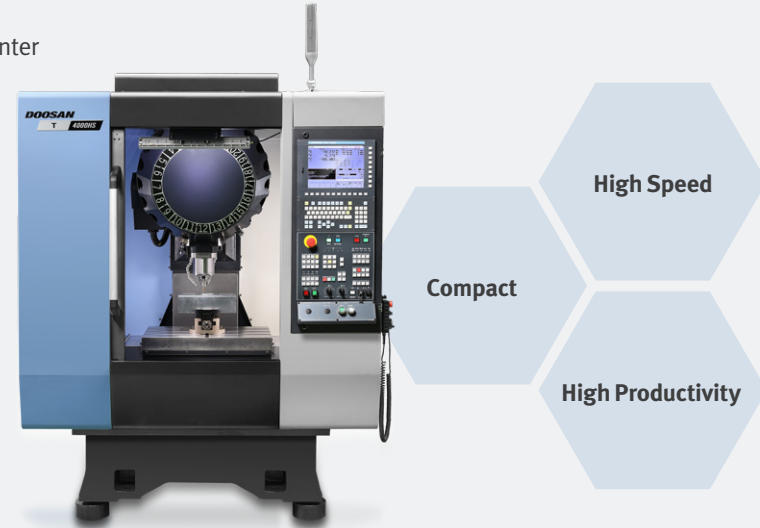

High speed machining solution

Max. Spindle speed
24000 r/min

New spindle cartridge

Oil-Lubrication for
high reliability and
endurance

Ultra-fine cutting: FANUC 31i

Rapid Traverse **48 m/min (1889.8 ipm)**



Spindle Thermal Error Compensation System (standard)

Thermal error of the spindle is calculated with the spindle temperature feedback and automatically compensated to maintain the highest level of work accuracy.

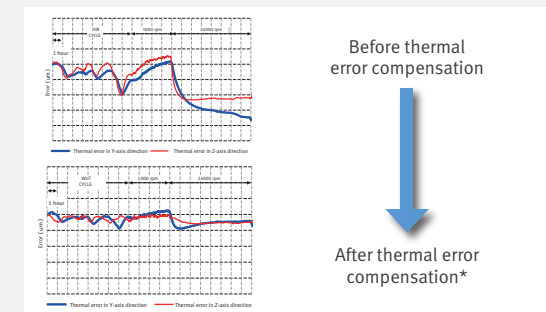

* T 4000, 18000 r/min, In-house measurement

Intro

Front-End Process

Vacuum Equipment
Splaying/Cleaning/
Heating
Polishing/
Metalization
Transfer System

Back-end Process

Wafer Inspection
Molding
Chip Inspection

Others

Frame/Cover

Workpiece

Frame



Material
Metal

Manufacturing Specialty

Big size part machining

Solution

BM series

Double Column Machining Center



For big size parts machining

Stroke (X x Y-axis)

BM 1530
3000 x 1550 mm
(118.1 X 61.0 inch)

BM 2035
3500 x 2050 mm
(137.8 X 80.7 inch)

BM 2740
4000 x 2700 mm
(157.5 X 106.3 inch)

BM 1530 & BM 2035 &
BM 2740
Z-axis **800 mm** (31.5 inch)



DBC series

Horizontal Boring Machine



X/Y/Z Stroke

4000 / 2500 / 2000 mm
(157.5 / 98.4 / 78.7 inch)

Max. Workpiece diameter(without Splash guard)

■ DBC 130 II / 250 II
Ø3900 mm (Ø153.5 inch)

■ DBC 130L II / DBC 160 /
L / 250L II
Ø4800 mm
(Ø189.0 inch)

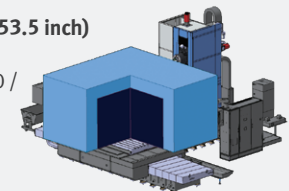

Doosan Machine Tools in the World

In an effort to provide solutions that fit each partners' unique needs, we constantly innovate our thinking, processes, and the way we do business. These optimal solutions lay the foundation for the success of our partners, which adds value to our partners' businesses.

Global Sales and Service Support Network

4 Corporations
167 Dealer Networks
51 Technical Centers
200 Service Post
3 Factories

Technical Center: Sales Support, Service Support, Parts Support

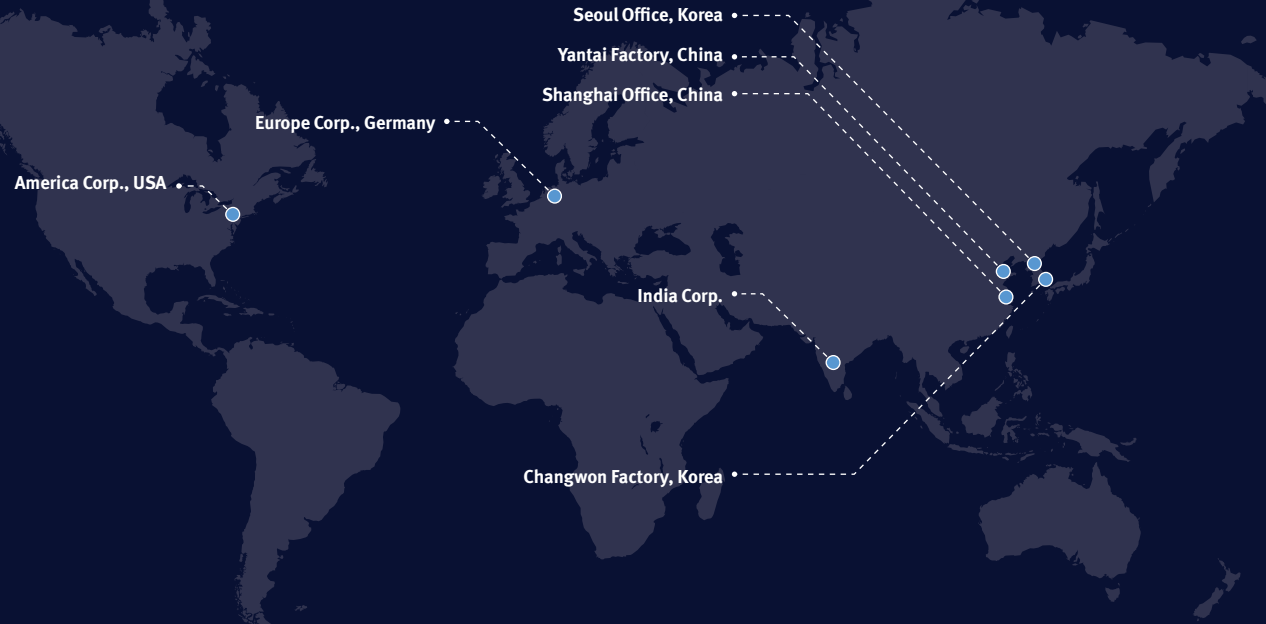

Supplying Parts

- Supplying parts without charges
- Supplying parts with charges
- Parts repair



Field Services

- On-site services
- Installment and trials
- Scheduled maintenance/ Preventive maintenance
- Repairs with/without charges



Technical Support

- Supporting machining technology
- Responding to technical inquiries
- Providing technical materials



Training

- Programming / Machine operation
- Maintenance
- Application engineering

Doosan Machine Tools

www.doosanmachinetools.com



Head Office

22FT Tower, 30, Sowol-ro 2-gil, Jung-gu, Seoul, Korea, 04637
Tel +82-2-6972-0370 / 0350
Fax +82-2-6972-0400

Doosan Machine Tools America

19A Chapin Rd., Pine Brook, NJ 07058, U.S.A.
Tel +1-973-618-2500
Fax +1-973-618-2501

Doosan Machine Tools Europe

Emdener Strasse 24, D-41540 Dormagen, Germany
Tel +49-2133-5067-100
Fax +49-2133-5067-111

Doosan Machine Tools India

No.82, Jakkur Village, Yelahanka Hobli, Bangalore-560064

Doosan Machine Tools China

Room 101,201,301, Building 39 Xinzhuan Highway No.258 Songjiang District,China Shanghai(201612)
Tel +86-21-5445-1155
Fax +86-21-6405-1472

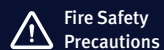

Fire Safety Precautions

There is a high risk of fire when using non-water-soluble cutting fluids, processing flammable materials, neglecting use coolants and modifying the machine without the consent of the manufacturer. Please check the SAFETY GUIDANCE carefully before using the machine.

- * For more details, please contact Doosan Machine Tools.
- * The specifications and information above-mentioned may be changed without prior notice.
- * Doosan Machine Tools Co., Ltd. is a subsidiary of MBK Partners. The trademark **DOOSAN** is used under a licensing agreement with Doosan Corporation, the registered trademark holder.